



JEVEN UV-CONTROL G1

Installation Guide

Dokument Nr 500-00039

Revision B



Jeven

Top ventilation for top chefs



CONTENT

PRODUCT DESCRIPTION	3
SOFTWARE FEATURES	3
TECHNICAL DATA	3
DELIVERY CHECK	4
ELECTRICAL INSTRUCTION	5
WIRING.....	6
SETTINGS AND OPERATIONS	7-21
MODBUS INSTALLATION	22
MODBUS COMMUNICATION.....	23
MODBUS CHANGE IP ADRESS.....	24-26

PRODUCT DESCRIPTION

Jeven UV-Control controls and monitors UV-TurboSwing filters. With continuous monitoring of run time and UV-light sources, the function of UV treatment is ensured.

Jeven UV-Control starts/stops all UV-Turbo filter. Operating periods for the kitchen can be set by a weekly timer, Monday to Sunday according to the needs the user has. The system can also be run manually or by way of external start/stop signal.

UV-Turbo filters run time is measured and emits alarms when the UV-lamp's maximum run time is reached. (Max run time UV-lamps 8 000 h).

Jeven UV-Control monitors the UV-lamps if they break before the maximum operating time is reached and alarms.

When the maximum operating time is reached, there is a possibility to reset the time, if replace of an individual UV-lamp before the maximum operating time has been reached, should not the time be reset.

Sum alarm from from Jeven UV-Control can be passed to an superior system by a potential-free contact.

SOFTWARE FEATURES

- Start and stop of UV-Turbo filter is selectable between: Manual, Week timer or External signal.
- Control of operating time, alarm at reached value.
- Ability to reset operating time.
- Control of the total ampere value of the UV lamps in the system, alarm if one breaks down.
- Potential free relay output to superior system in case of alarm.

TECHNICAL DATA

Dimension:	200x200x120mm (WxHxD)
Power supply:	230VAC, 10A
Protection:	IP65
Ambient temperature:	<55 ° C
Maximum number of UV-Turbo filter:	25pcs

DELIVERY CHECK

Control that the insulation box and cables doesn't have any defects. Defective material can not be assembled and put into operation. Contact Jevan AB for handling of defective material.

Delivery includes:

- Jevan UV-Control



- Safety switch



- Connected cables. 5m or 10 m



- Jevan Plug & Play box, 1 piece / hood
Mounted on the ceiling of the hood



ELECTRICAL INSTRUCTION

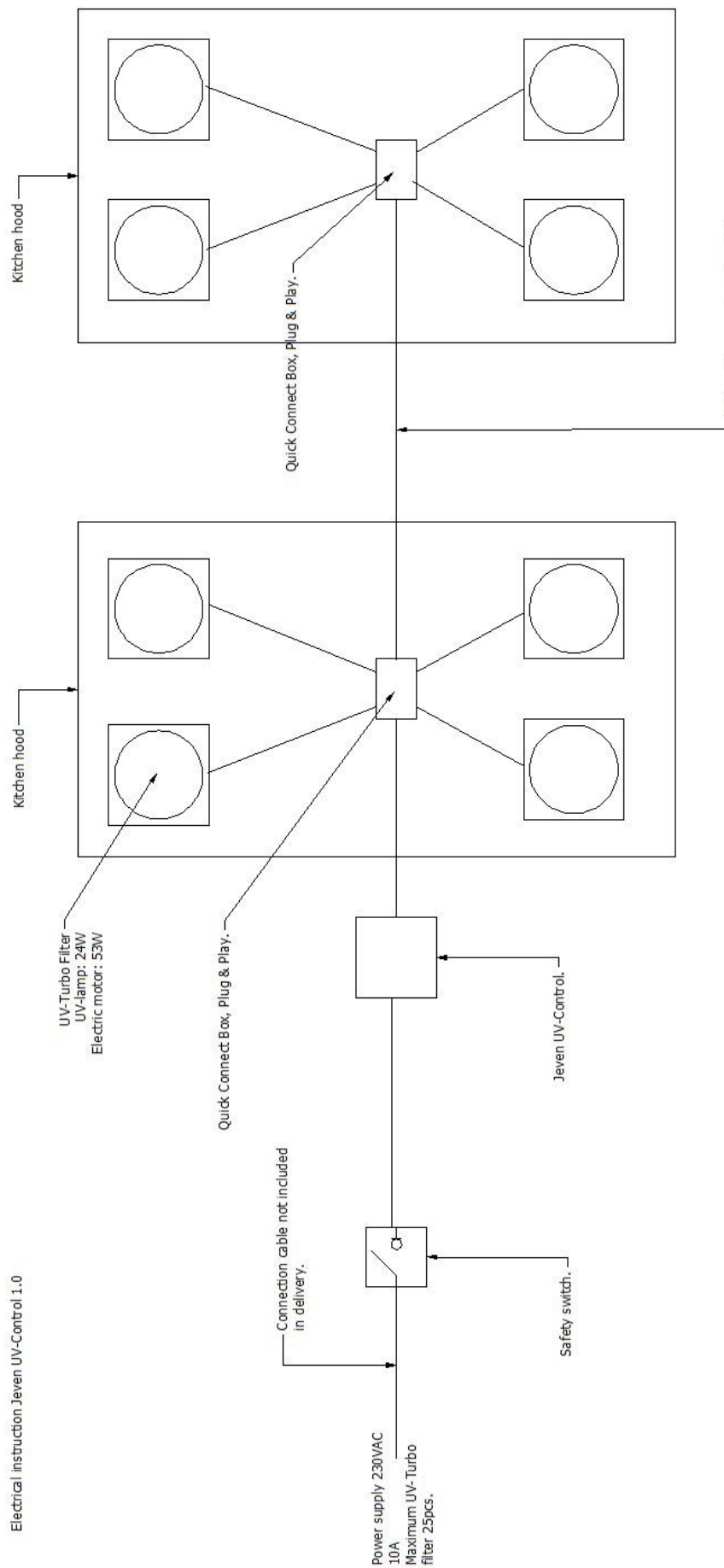

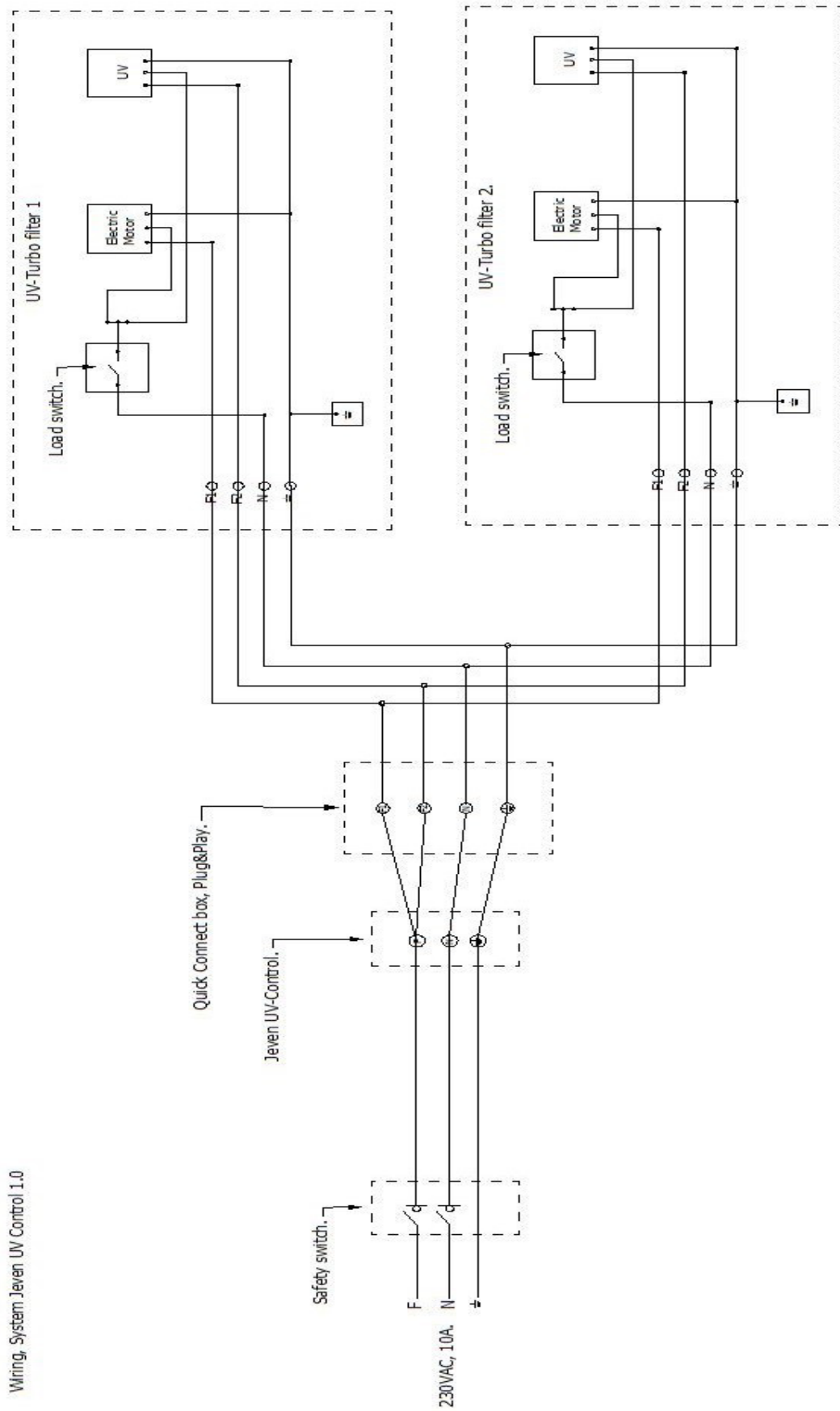

SETTINGS AND OPERATIONS

Jeven UV-Control has three different possibilities for start and stop of the UV-Turbo filters, monitoring the UV-lamps and keeping track of the UV-lamps operating time. As well as the ability to adjust the alarm limit for the ampere measurement, if for example retrofitted into one or more UV-Turbo.



CONTENT

1. CONTROL FUNCTION

- 1.1 Manual Start/Stop
- 1.2 Start/Stop with weekly timer
- 1.3 Start/Stop by external signal

2. RUN TIME

- 2.1 Read current run time

3. ALARM

- 3.1 Alarm UV-lamp
- 3.2 Alarm run time
- 3.3 Alarm cleaning
- 3.4 Sum alarm
- 3.5 Operation indication

4. PROGRAMMING ALARM LIMIT

SETTINGS AND OPERATIONS

1. CONTROL FUNKTION

1.1 Manual start/stop



To stop the UV-purification manual press
(Esc + ◀)

SETTINGS AND OPERATIONS

1. CONTROL FUNCTION

1.2 Start and stop with weekly timer

To enter the program menu, press ▼ then Esc.

In the program select: 1. "Program", 2 "Set parameter" and 3. "WEEKLY TIMER".



Here you can use up to 3 different time programs D1, D2 and D3.

Example:

D1	D2
M, T, W, T, F	S, S
On1	On2
07:00	10:00
Off1	Off2
16:00	14:00



Exit the program menu by pressing Esc until, time and date appear on screen, then press arrow ▲.

SETTINGS AND OPERATIONS

1. CONTROL FUNCTION

1.3 Start/Stop by external signal

Connect control cable to input I8 on Siemens LOGO! When using 230VAC signal.
Or use the 24VDC relay to activate Start/Stop by 24VDC signal.

Start of the system occurs when input I8 on Siemens LOGO! will go in "high" state over 79VAC.
Stop of system occurs when the voltage level is below 30VAC, the input I8 on Siemens LOGO! will go in "low" state.

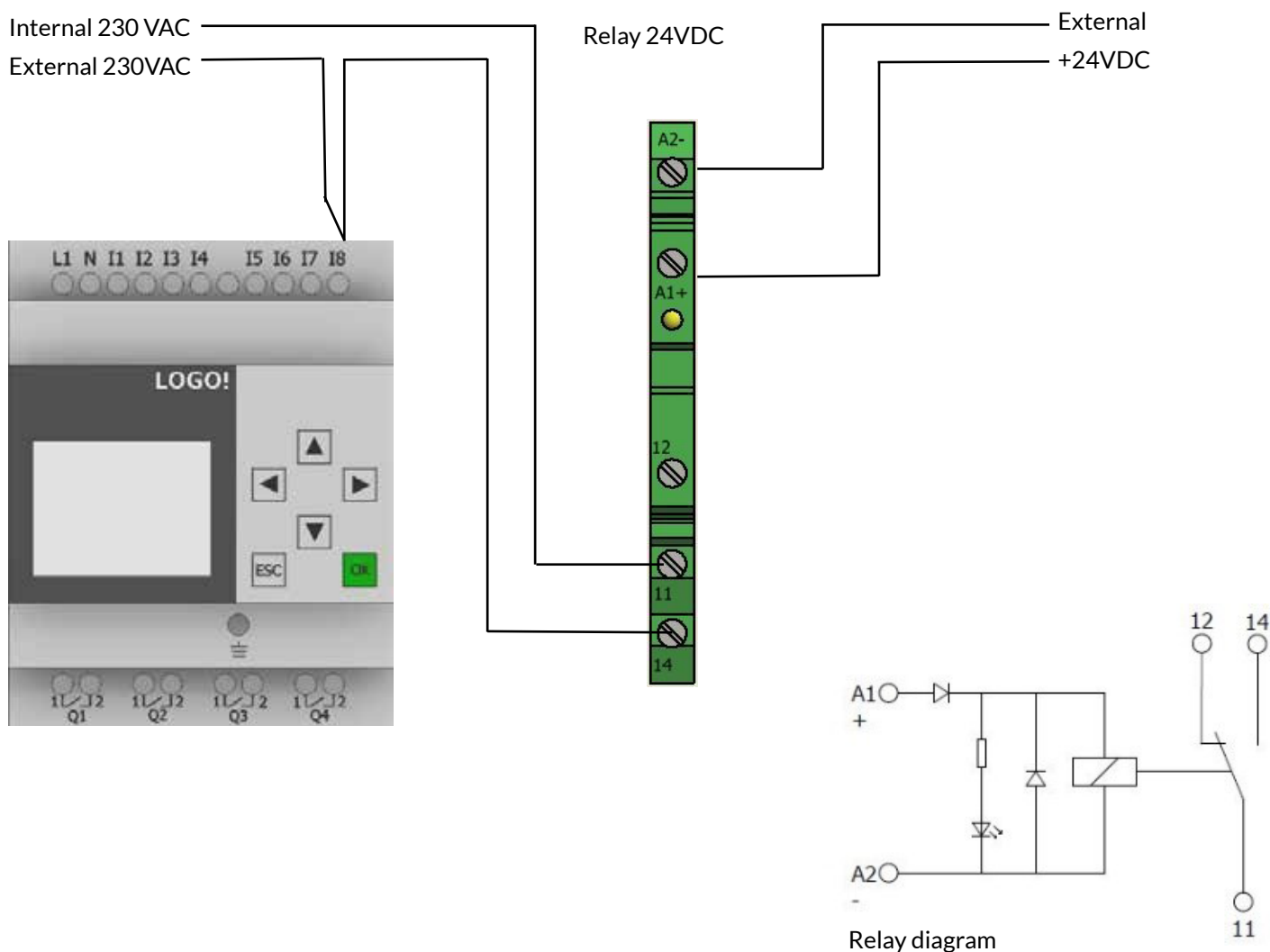

SETTINGS AND OPERATIONS

2. RUN TIME

2.1 Read current run time

Current operating time is read
by simultaneously pressing:
Esc + ►



UV lamps have a lifespan of 8 000 h, then they should be replaced. The system will indicate when the run time of 8 000 h has been reached.

SETTINGS AND OPERATIONS

3. ALARM

3.1 Alarm UV-lamp

If a UV-lamp is broken, the system detects power loss and generates an alarm.

Then it needs to be physically checked which filter house the diode labeled UV does not light blue. When it is determined which UV light is broken, byts den. The alarm is reset automatically when the current limit returns to the normal level



3.2 Alarm run time

Jeven UV-Control has built-in control of the run time of the UV-lamp, the system will give an alarm when 8 000 h are reached, which is the lifespan of the UV-lamps. Replace all UV-lamps and reset run time by pressing ESC + ▼



SETTINGS AND OPERATIONS

3. ALARM

3.3 Alarm cleaning

There is a possibility to set a cleaning interval in the Siemens LOGO!.
The service function is OFF by default.



Set the cleaning status to ON.



Adjust the cleaning interval if necessary. Default time is set to 10h (On =+00010).

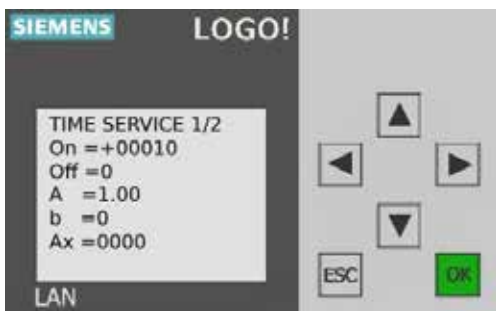

SETTINGS AND OPERATIONS

3. ALARM

3.4 Sum alarm

There is a possibility of connecting to the superior system and receiving a signal when an alarm has been triggered. Connect any voltage, Max 240VAC/VDC to the potential-free relay output Q1 (NO) on Siemens LOGO!

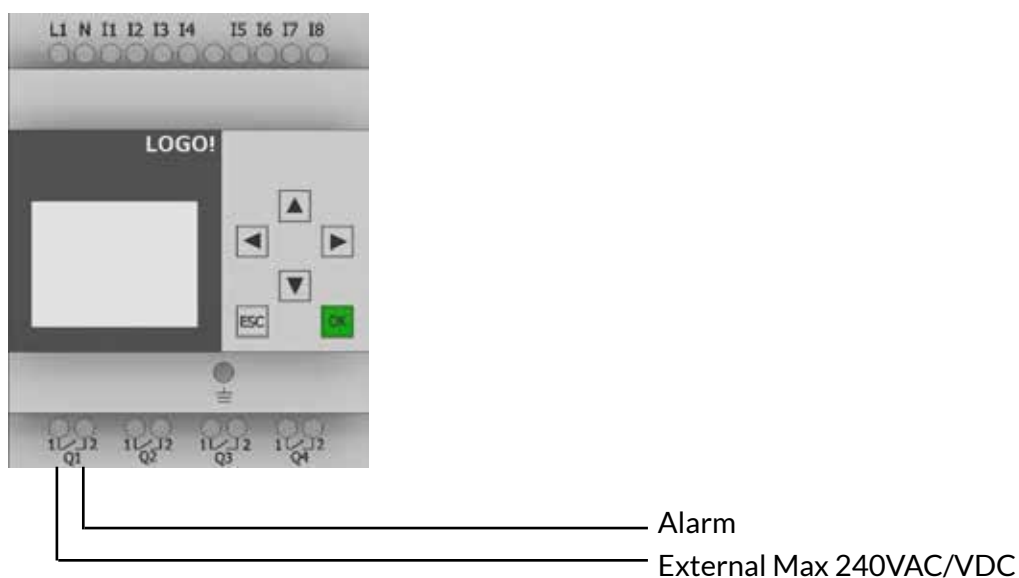

3.4 Operation indication

It is possible to get an operation indication from Siemens LOGO! Connect any voltage, Max 240VAC / VDC to the potential-free relay output Q4 (NO) on the Siemens LOGO!

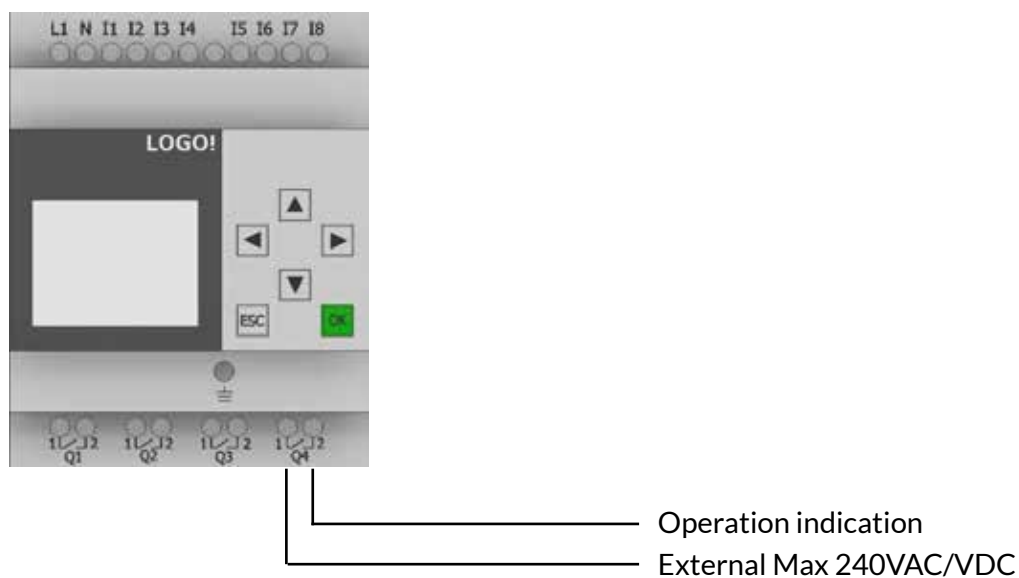

SETTINGS AND OPERATIONS

4. PROGRAMMING ALARM LIMIT

The monitoring of the UV lamps is done by measuring the total current value of all UV-lamps in the installation. Should a UV-lamp break, the system detects the current change and displays the alarm on Siemens LOGO! and triggers the potential-free relay output Q1 on Siemens LOGO!

Due to the low power consumption from one UV-lamp (0.1A), the current relay Finder 71.51 is programmed with the internal power transformer for a more stable current measurement. This means that the visual value shown on the Finder 71.51 display is only a fictional value. Jeven UV-Control is delivered pre-programmed and calibrated for each project/kitchen.

The following is instructions for calibration of the system:

- Start the system and check all filters that the LED labeled UV lights blue, then read on the Finder 71.51 display, what the current current value is.



- Take down a grease collector in the kitchen hood closest to Jeven UV-Control, read which current value is now displayed on the Finder 71.51 when a UV-lamp has been turned off.

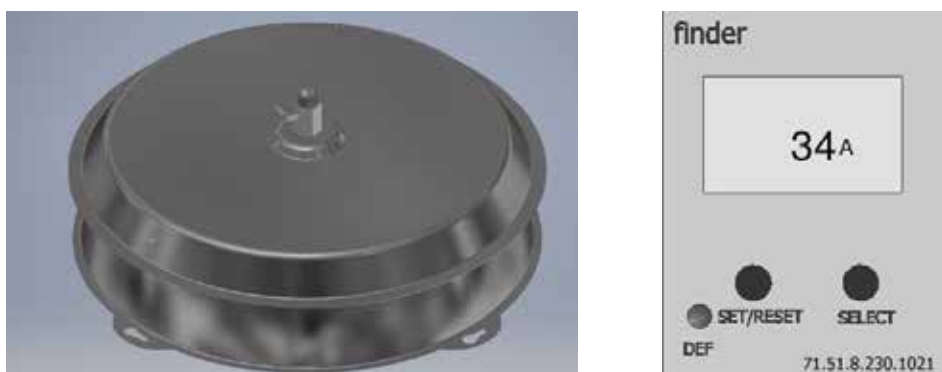

SETTINGS AND OPERATIONS

4. PROGRAMMING ALARM LIMIT cont.

- The alarm limit should have a value between fully operational system and when one (1) UV-lamp is disconnected, as exemplified above: Fully functional 40A, one (1) UV lamp off 34A. The alarm limit should then have a value of 37A.

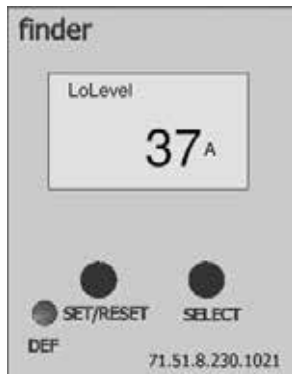

- To check the current alarm limit and the ability to adjust it, you need to enter the Finder 71.51 programming view. Accessing the programming view is achieved by holding down the "Set/Reset" and "Select" buttons at the same time for 3 seconds.

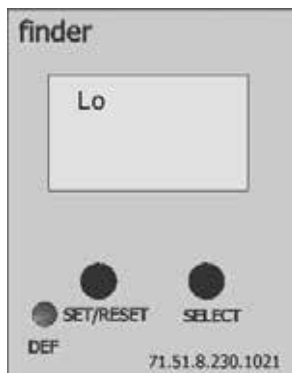

SETTINGS AND OPERATIONS

4. PROGRAMMING ALARM LIMIT cont

- Screen 1: Displays us to measure alternating current AC, this must not be changed!
Press the "SET / RESET" button to proceed.



- Window 2: Here is the value of the internal power transformer, this must not be changed!
Press the "SET/RESET" button to proceed.

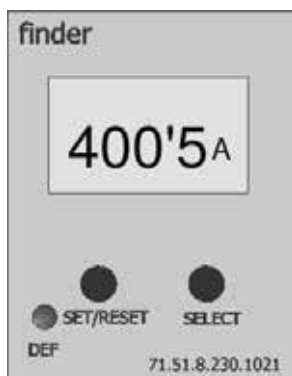

- Window 3: Here you choose if you want to measure under or overcurrent, the system should measure undercurrent and may not change!
Press the "SET / RESET" button to proceed.

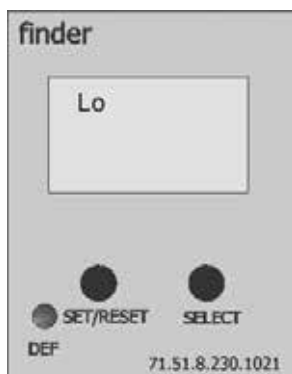

SETTINGS AND OPERATIONS

4. PROGRAMMING ALARM LIMIT cont

- Window 4: Here you can change the alarm limit for the UV current, check which level is programmed and change if necessary. Use the "SET/RESET" button to move the cursor in the window, change the digits by pressing the "SELECT" button until the correct number is on the window. As in the example above we would have 37A. Press the "SET / RESET" button to proceed.

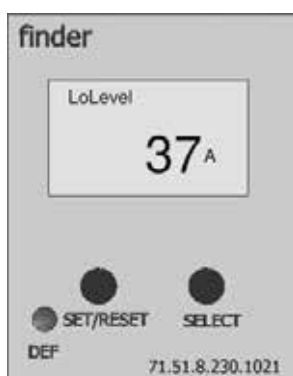

- Window 5: Here is the value of the preprogrammed hysteresis value, this must not be changed! Press the "SET / RESET" button to proceed.



- Window 6: (T1) Here you program a delay of outgoing alarm when it has detected a current loss, Finder 71.51 is programmed with a delay of 10 seconds. This value should not be changed. Press the "SET/RESET" button to proceed.



SETTINGS AND OPERATIONS

4. PROGRAMMING ALARM LIMIT cont

- Window 7: (t2) A delay is programmed here when the Finder 71.51 starts to do the undercurrent measurement, the delay is programmed with 10 seconds for the current to be stable before measurement. This value should not be changed!
Press the "SET / RESET" button to proceed.

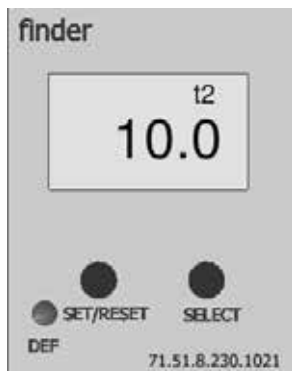

- Window 8: Selection of memory function, memory function should not be used.
Do not change!
Press the "SET/RESET" button to proceed.



SETTINGS AND OPERATIONS

4. PROGRAMMING ALARM LIMIT cont

- Window 9: Concluding window, Press the "SET/RESET" button to exit the programming view. If there is a need to continue from the beginning again, press the "SELECT" button.

Start the system again and take down a grease collector, the system will now detect the power loss and generate an alarm.



Refit the grease collector and reset the alarm by pressing ESC + ▲.

MODBUS

INSTALLATION

Use standard Ethernet TCP/IP RJ45 Cat 6 cable to communicate with superior system, see example below:



Connect one side of the Ethernet cable to Siemens LOGO: X1 P1 IE(LAN), see picture below:



Connect the other side of Ethernet cable to the superior system, see example below:

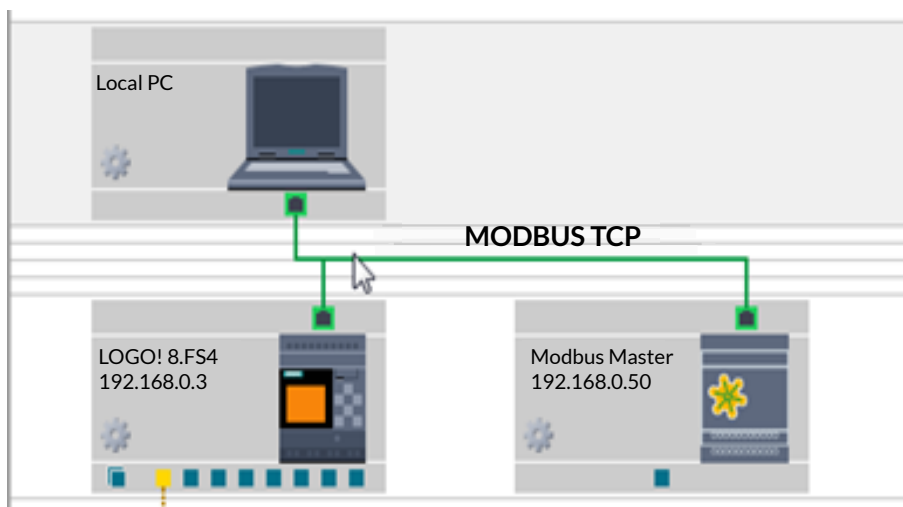

MODBUS

COMMUNICATION

LOGO! Handles up to 16 pcs. connections simultaneously over the Profinet or Modbus protocols. This means that it is possible e.g. connect 16 Modbus slaves under a logo, or that 16 Modbus masters communicates with one and the same Logo! Default is LOGO! configured in slave mode. The maximum update time for Modbus communication is 100 ms.

Function	LOGO	Modbus
Start/Stop	V0.0	1 (Coil)
Service alarm	V1.0	9 (Coil)
Sum alarm	V1.1	10 (Coil)
Operation indication	V1.2	11 (Coil)

Default IP Adress: 192.168.0.3

Netmask: 255.255.255.0

Netmask: 255.255.255.0

MODBUS

CHANGE OF IP ADRESS IN SIEMENS LOGO!

It is necessary to change the IP address to match the IP address of the facility. Follow the steps below to set the correct IP address:



Press the down arrow ▼.

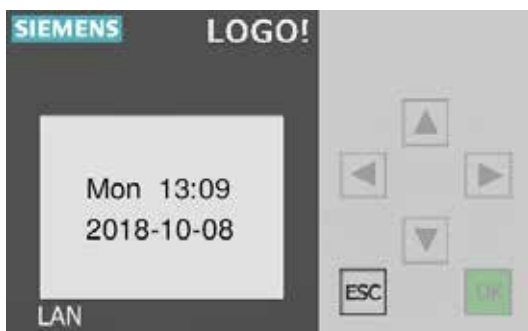

Then press ESC



Set the cursor to "Stop" and press OK.

MODBUS

CHANGE OF IP ADRESS IN SIEMENS LOGO!



Stop program "Yes" and press OK.



Set the cursor to "Network" and press OK.



"IP Address" press OK.

MODBUS

CHANGE OF IP ADRESS IN SIEMENS LOGO

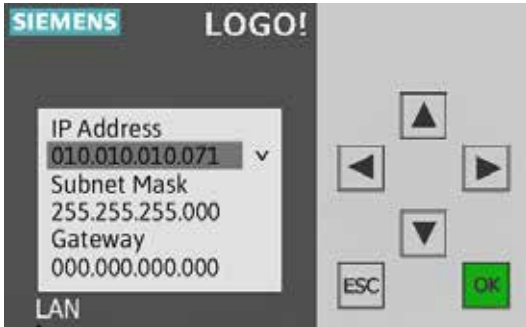

Press OK to start changing the IP address, use the arrow keys to change the numbers and move sideways. When the correct IP address is set, press OK.

Do the same to change the Subnet Mask.

When both addresses are set, press ESC twice.

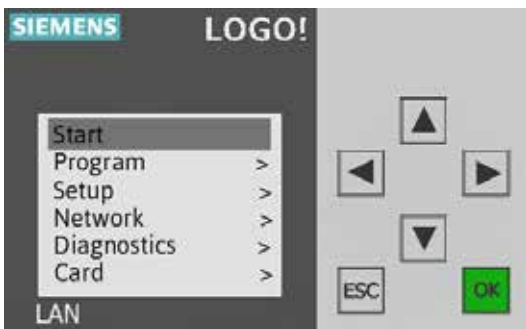

Set the cursor to "Start" and press OK.



Start program "Yes" and press OK.

The IP address has now been changed!

CONTACT

Jeven AB
Växelgatan 15
S-826 40 Söderhamn

+46(0)270-731 40
jeven@jeven.se
www.jeven.se

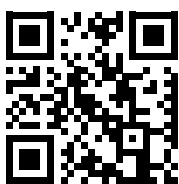

UV Turbo

by **Jeven**

Jeven
Top ventilation for top chefs